

AD600 Driving Assistance Equipment

Product Manual

Document Version: Driving Assistance Equipment_Product Manual_V1.0

Hardware version: AD600_V2.1_2022/10/28

Date: 08/08/2023

Status: Controlled document

Version Modification Record

Version number	Presenter	Examined and approved	Modification content	Modification date
V1.0			Initial version	2023.08.08

Introduction

This document is applicable to the driving assistance device AD600, to guide users in convenient and quick installation and application.

Target audience

This document is mainly applicable to the following engineers:

- System Design Engineer
- Structural Engineer
- Hardware Engineer
- Test Engineer
- Installation Engineer

TABLE OF CONTENTS

AD600 Driving Assistance Equipment	1
Introduction	3
1. Product introduction	6
1.1. Product overview	6
1.2. Product schematic diagram	6
1.3. Packing contents	7
2. Hardware specifications	8
2.1 AD600 Detailed Specifications	8
2.2. LED indicator light	9
3. Introduction to software functions	10
3.1. Product advantages & features	10
3.2. Product features:	11
4. AI functions	12
4.1. ADAS functions	12
4.1.1. Front collision warning	12
4.1.2. Pedestrian collision warning	13
4.1.3. Lane departure warning	14
4.1.4. Virtual bumper	14
4.1.5. Starting the car	15
4.2. DMS functionality	15
4.2.1. Fatigue driving alarm	15
4.2.2. Distracted Attention Warning	16
4.2.3. Smoke Alarm	16
4.2.4. Phone Dialing to report an emergency	17
4.2.5. Seat Belt Detection	17
5. Installation instructions	18
5.1. Installation location related regulations	18
5.2. Installation location recommendations	19
5.3. Installation instructions	20
6. Viidure APP settings	22

6.1. ViidureAPP installation and preparation	22
6.2. Connect AD600 in the app	23
6.3. Recorder Settings - Algorithm Settings	24
6.4. ADAS & DMS Calibration	25
7. Firmware upgrade	27
8. Usage precautions	29
8.1 Warning	29
8.2 Maintenance Precautions	30
8.3 Simple Troubleshooting	30
9. Conclusion	31

1. Product introduction

1.1. Product overview

AD600 is a comprehensive automotive active safety product that integrates functions such as satellite positioning, video monitoring, and active safety. This product meets the needs of fleet monitoring, management, driver safety, and compliance with driving behavior. Based on advanced deep learning technology, active safety features such as Advanced Driver Assistance Systems (ADAS), Driver Monitoring Systems (DMS), Lane Change Assist (LCA), and other intelligent algorithms can be applied to complex driving scenarios to enhance the safety and efficiency of traffic driving, improving the overall user experience. Artificial intelligence technology integrated into the vehicle driving process can further standardize the driver's safe driving behavior.

This product supports the national standard protocols such as JT/T808, JT/T905, JT/T1078, etc., meeting the needs of video surveillance and regulation of driving behavior for online car-hailing, taxi, and logistics fleets.

1.2. Product schematic diagram



1.3.Packing contents

Package contains the following items:

1. AD600 device (dual recording)
2. SOS button
3. GPS antenna
4. T-card baffle, small screw X2 for baffle, large screw x2 for locking camera
5. SIM card holder and card removal pinPower cord
6. Third camera (optional)

AD600 device (dual recording integrated)	
Alarm button	
External GPS antenna	
Power cord	
Camera 3 (optional)	
<p>Accessory: T-card baffle, small screw X2 for baffle, large screw x2 for locking camera</p>	

2. Hardware specifications

2.1 AD600 Detailed Specifications

Host item	
CPU	Dual-core, 1.2GHz
RAM	2GB 16-bit DDR3(L) memory
Wi-Fi	support
4g	support
GPS	support
Video/Audio	
Video format	H265/H264
Audio format	PCM, WAV
Built-in speaker	Support, monaural
Built-in microphone	Support, monaural
Front camera	
sensor type	1/2.9", 2 million pixel CMOS sensor
FOV	D:125° H:105° V:58°
resolution	1920*1080
Frame rate	1080p@30fps
Internal camera	
sensor type	1/3", 2 million pixel CMOS sensor
FOV	D:120°H:100° V:45°
FOV	1920*1080
resolution	1080p@30fps
Other	
operating system	Linux
mains	Power supply voltage 9-36V

G-Sensor	3-axis, accelerometer
storing	Supports TF card, up to 256GB, Class 10 and above, FAT32.
Shell	
Type	Independent
Color	Black
weight	198 grams
Dimensions	116mmx66mmx38mm
Operating environment	
Operating temperature	-20°C~+70°C
Storage temperature	-30°C~+80°C
Relative humidity	10% to 90%, non-coagulation
Atmospheric pressure	860 millibars to 1060 millibars
Package contents	
AD600 device ×1, emergency button ×1, external GPS antenna ×1, SIM card eject pin ×1, power cord ×1	
*Configurations may vary in different countries and regions.	

2.2. LED indicator light

The following image shows the position of the LED:



The table below shows the status of the LED:

LED	Color	Status	picturing
Recording light	Red/Blue	Close	Power disconnected.
		Blue is always on	The system is running normally, but not recording.
		Red is always on	Video recording
4G Light	Yellow	Close	No 4G signal.
		Blink	There is a platform with 4G signal that has not been launched.
		Bright	There is a 4G signal and go online on the platform.
GPS light	Green	Close	No GPS signal.
		Blink	GPS signal not positioned
		Bright	Has GPS signal and successfully positioned.

3. Introduction to software functions

3.1. Product advantages & features

- ◆ Support multiple high-definition videos.

- ◆ Supports 4G internet data transmission and positioning.
- ◆ Voice support for intercom/listening
- ◆ Remote real-time positioning and trajectory playback
- ◆ Remote real-time video and playback
- ◆ AI alarm video upload
- ◆ Support ADAS/DMS automatic identification calibration.
- ◆ Advanced Driver Assistance Systems (ADAS)
- ◆ Driver Behavior Monitoring Function (DSM)
- ◆ Support DMS left and right steering wheel settings.
- ◆ Support driver DMS and integrated video monitoring in the car.
- ◆ RS232/IO and other extensions

3.2. Product features:

Function		Functional description
Positioning function	Position report	Regular reporting
Recorder	Video Recording	Local video recording
Alarms	Speeding warning	The vehicle speed is less than the maximum speed and meets the overspeed warning threshold.
	Speeding alarm	The speed exceeds the maximum speed.
	Fatigue driving	Continuous driving exceeds the specified time.
	Total driving alerts for the day	Exceeding the specified driving time on the same day.
	Overtime parking alarm	Parking exceeds the specified time.
	Emergency alarm	Trigger emergency alarm button.
	"Manually confirm the alarm."	support
Parameter query	Query terminal properties	Terminal parameters, including online IP, port, etc.
Parameter settings	Set terminal parameters	Terminal properties include terminal type, terminal model, etc.

upgrading	Remote upgrade (8108)	support
	Text message distribution	Includes protocol TTS broadcasting and custom functions including FTP remote upgrade, parameter modification, etc.
Multimedia	Take a photo immediately.	Remote photo taking
	Multimedia upload	support
	Multimedia retrieval	support
Audio, video	Real-time video	support
	Video playback	support
	Audio and video download	support
	Intercom	support
	Monitor	support
	Route area settings	support

4. AI functions

This device uses machine vision technology based on video analysis to automatically identify road hazards and unsafe driving behaviors of the driver. Any detected event will trigger a sound alarm to instantly alert the driver, and these events will also be synchronized on the platform.

Note: AI functionality must be calibrated and configured according to the installation instructions, otherwise, the accuracy of AI functionality may be affected.

Algorithm warning trigger condition: Trigger speed greater than 30km/h.

Outdoor testing: Verify device connection to GPS antenna, use GPS speed.

Indoor testing: Method 1 After connecting to the mobile app, enter the recorder settings - click on the firmware version once to prompt that the simulated speed has been turned on - the device will restore after restarting.

Method 2: Put the simulated speed text into the root directory of the T card - insert the device - prompt that the simulated speed has been opened - the device will restart to take effect.

4.1. ADAS functions

4.1.1. Front collision warning

Function: Real-time recognition of the relative speed between the vehicle and the preceding vehicle during driving, reminding the driver when a collision is possible, ensuring sufficient emergency braking time.

Trigger conditions: When the vehicle's driving speed is greater than the minimum warning speed and there is a vehicle ahead in the current trajectory, an alert will be issued if the estimated collision time is less than the safe collision time.

Minimum warning speed (km/h): Default value > 30, adjustable from 10 to 90.

• Sensitivity: High, Medium, Low (default: Medium)

- a. High $ttc \leq 3.5$ s
- b. The ttc is less than or equal to 2.7 seconds.
- c. Low $ttc \leq 1.8$ s

Voice prompt: Pay attention to the front vehicle.

4.1.2. Pedestrian collision warning



Function: In the process of driving, real-time recognition of pedestrians, bicycles, and motorcycles in front of the vehicle, and if there is a potential collision danger, it will alert the driver to ensure sufficient emergency braking time.

Trigger condition: The vehicle is traveling at a speed within the warning speed range, and the distance between the pedestrian in front and the vehicle is less than 5m.

Minimum warning speed: default value 10-60 km/h

• Sensitivity: High, Medium, Low (default: Medium)

- a. High $absttc \leq 1.6$ s warning range, 0.1 meters outside the vehicle.
- b. $absttc \leq 1.3$ s Warning range, 0 meters outside the vehicle.
- c. Low $absttc \leq 1$ s warning range, vehicle outside -0.1 meters.

Voice prompt: Watch out for pedestrians.

4.1.3. Lane departure warning



Function: Real-time recognition of lane departure behavior during driving, if there is any unconscious lane departure behavior, it will remind the driver to ensure driving safety.

Trigger condition: The vehicle's driving speed is greater than the minimum warning speed, and there is no turn signal (if connected). The vehicle deviates from the center of the lane and presses against a lane line that is clearly recognizable to the naked eye.

Minimum warning speed (km/h): Default value > 30, adjustable from 10 to 90.

The distance between the front car and the rear car is less than or equal to (3~5) meters, and the two cars are approaching each other.

- a. High. Distance from the outer side of the wheel to the lane line: ≤ 0.15 meters. Time to cool down and adjust the lane change: 0.7 seconds.
- b. Distance from the outer side of the wheel to the lane line: ≤ 0 meters. Time to cool down and adjust the lane change: 1 second.
- c. Distance from the outer edge of the wheels to the lane line: ≤ -0.15 meters. Lane change alignment cooling time: 1.5 seconds.

Alarm voice prompt: Lane departure

4.1.4. Virtual bumper



Function: When the vehicle is traveling at low speed, it recognizes the relative speed between the own vehicle and the preceding vehicle. When there is a potential collision danger, remind the driver to maintain a safe distance.

Minimum warning speed (km/h): 1-30

• **Sensitivity:** High, Medium, Low (default: Medium)

- a. High and the distance to the preceding vehicle is less than or equal to (3~5) meters and the two vehicles are approaching each other.

- b. The distance between the vehicles is $\leq (2\sim 4)$ meters and the two vehicles are approaching each other.
 c `if (distance_to_front_car \leq 1-3 meters && cars_approaching_each_other) { // Code logic here }`

Voice prompt: Keep a safe distance.

4.1.5. Starting the car



Function: When the vehicle is in a stationary state, it reminds the driver to start moving when the vehicle in front starts moving.

- Sensitivity: High, Medium, Low (default: Medium)

a. When the vehicle stops for at least 4 seconds, the distance to the front vehicle is less than or equal to 6.5 meters. The time the front vehicle moves away is at least 0.6 seconds, and the distance it moves away is at least 0.6 meters.

Using GPS speed to determine when the vehicle stops.

b. When the vehicle stops for ≥ 5 seconds and the distance to the front vehicle is ≤ 6 meters, and the time the front vehicle moves away is ≥ 1 second, and it moves away by ≥ 1 meter.

Using GPS speed to determine when the vehicle stops.

c `if (vehicleSpeed \leq 5 && timeStopped \geq 5 && distanceToVehicleAhead \leq 6 && timeVehicleAheadAway \geq 2.5 && distanceVehicleAheadAway \geq 2) { // do something }`

Voice prompt: Please start.

4.2. DMS functionality

4.2.1. Fatigue driving alarm



Function: Identify the driver's fatigue state (closing eyes, yawning) and issue warnings to ensure driving safety.

Minimum warning speed (km/h): Default value > 30 , adjustable from 10 to 90.

- Sensitivity: High, Medium, Low (default: Medium)

a. High: When the eyes are closed or the mouth is open for a duration of at least 1 second, the ratio of the height to width of the lips is greater than or equal to 0.4.

b. Close your eyes or open your mouth for a duration of 2 seconds or more, with a lip height-to-width

ratio of 0.5 or greater.

- c Low: Close eyes or open mouth time ≥ 3 s, lip height-to-width ratio ≥ 0.6 .

Voice prompt: Please remember to take a break.

4.2.2. Distracted Attention Warning



Function: Identify behaviors of drivers not looking at the road ahead (looking around, searching for something while driving) and sound an alarm to ensure driving safety.

Minimum warning speed (km/h): Default value > 30 , adjustable from 10 to 90.

• Sensitivity: High, Medium, Low (default: Medium)

a. High face pose time greater than or equal to 1s, pitch greater than or equal to 30 degrees or yaw greater than or equal to 30 degrees.

b. If the face pose exceeds the threshold for a duration of ≥ 2 seconds, with a pitch ≥ 35 degrees or yaw ≥ 35 degrees.

- c Low: Face pose greater than threshold time ≥ 3 s, pitch ≥ 40 degrees or yaw ≥ 40 degrees.

Voice prompt: Please focus on driving.

4.2.3. Smoke Alarm



Function: Identify the driver's smoking behavior during driving and issue warnings to ensure driving safety.

Minimum warning speed (km/h): Default value > 30 , adjustable from 10 to 90.

• Sensitivity: High, Medium, Low (default: Medium)

- a. High smoking time ≥ 1 s

b. Smoking time $\geq 2s$

c if (smokingTime $\geq 3s$) { igniteCigarette(); }

Voice prompt: No smoking.

4.2.4. Phone Dialing to report an emergency



Function: Identify the driver's mobile phone usage behavior while driving and issue warnings to ensure driving safety.

Minimum warning speed (km/h): Default value > 30 , adjustable from 10 to 90.

• Sensitivity: High, Medium, Low (default: Medium)

a. High. Call duration $\geq 1s$.

b. When making a phone call, the duration should be at least 2 seconds and the phone should be held above the chin.

c . Low Call duration $\geq 3s$ Phone position needs to be above the chin Need to open mouth to speak

Voice prompt: Please do not use your mobile phone.

4.2.5. Seat Belt Detection



Function: Device recognizes seat belt status and issues a warning to the driver when driving without wearing a seat belt to ensure driving safety.

Minimum warning speed (km/h): Default value >30 , adjustable from 10-90.

• Sensitivity: High, Medium, Low (default: Medium)

a. High. Seatbelt not detected for $\geq 5s$.

b. No seat belt detected for $\geq 10s$.

c . Low Seatbelt not detected for $\geq 15s$

Voice prompt: Please fasten your seatbelt.

Demonstration diagram of wearing seat belts:



5. Installation instructions

5.1. Installation location related regulations

Note: The following suggestions do not constitute legal advice. Please comply with local laws and regulations.

Installation Position Regulations for Recorders - United States

According to the regulations of the Federal Motor Carrier Safety Administration (FMCSA), the onboard recording device is allowed to be installed in any of the following positions:

- From the top of the windshield to 8.5 inches below the upper edge of the area swept by the windshield wipers.

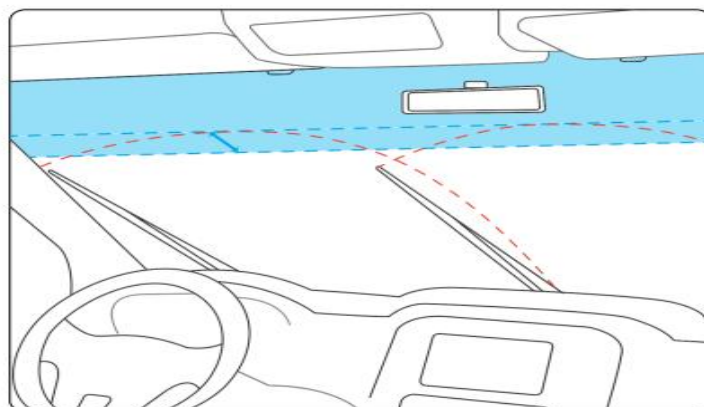

Installation Position Regulations for Recorders - United Kingdom

In order to determine the positioning of the recorder, the windshield is divided into several zones:

- Area A: A vertical area centered around the steering wheel, 29 centimeters wide (35 centimeters wide for vehicles weighing over 3.5 tons), swept by the windshield.
- Area B: The windshield sweeps over the remaining parts except for Area A.

Any part of the dashcam (including the bracket and wires) should not extend into Area A by more than 10 millimeters (1 centimeter), nor into Area B by more than 40 millimeters (4 centimeters).

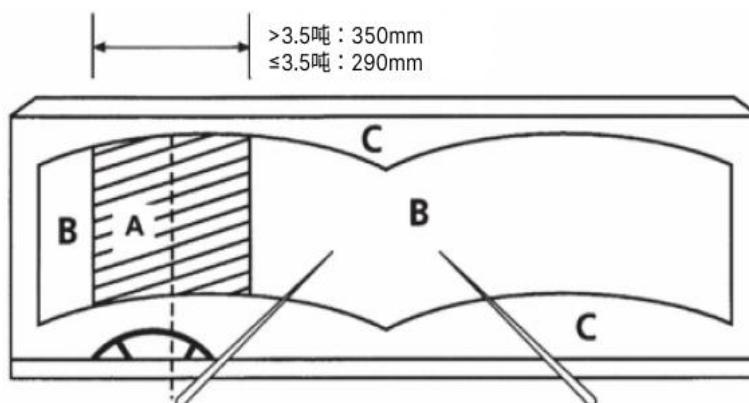

5.2. Installation location recommendations

It is recommended to install AD600 on the upper edge of the windshield directly above the steering wheel, as shown in the picture.

In order to ensure safe driving and maximize the accuracy of AI algorithms, the selection of device installation location needs to be based on the following principles:

- Do not block the driver's line of sight.
- Do not disturb the driver while driving.
- The device should be kept level and not tilted.
- The driver's face is best displayed in the center of the inward-facing camera's screen (preview can be viewed in the "viidure" app).
- It is best for the center point of the front camera image to align with the horizon (you can preview it in the "viidure" app).

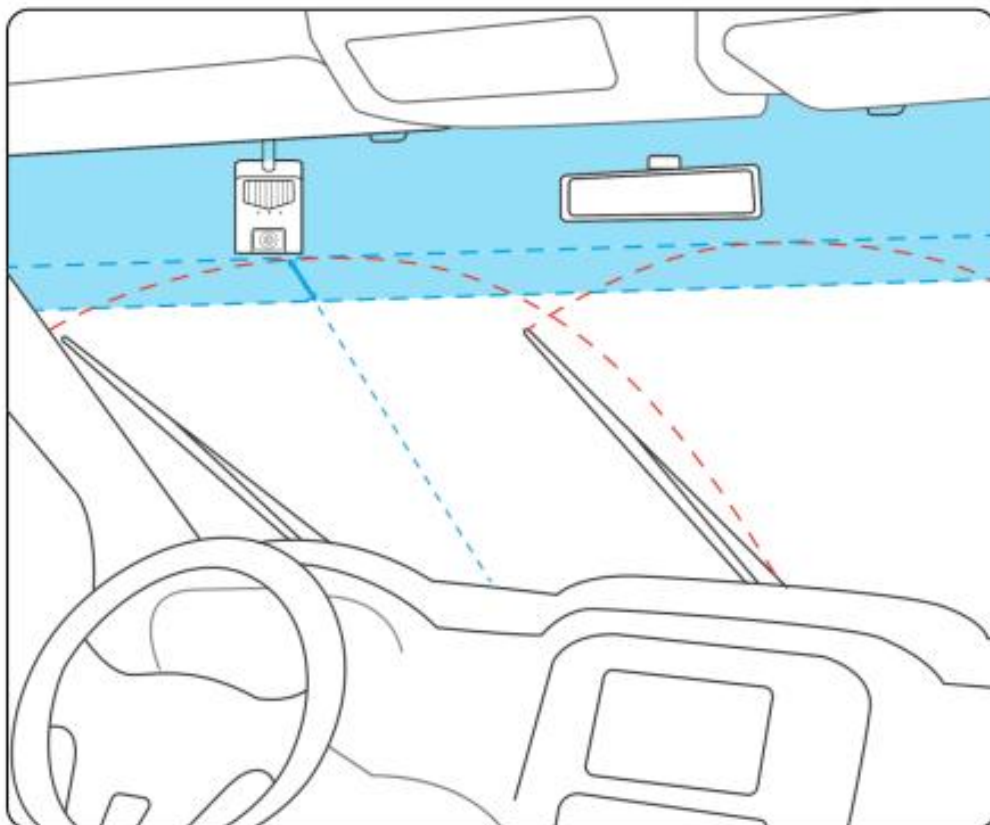

5.3. Installation instructions

Memory card installation



Remove the 2
screws and bezel
on the side of the
device and insert
the storage card

4G card installation



Use the provided
card retrieval pin to
remove the SIM
card slot and insert
the nano sim card

Installation diagram recommended:

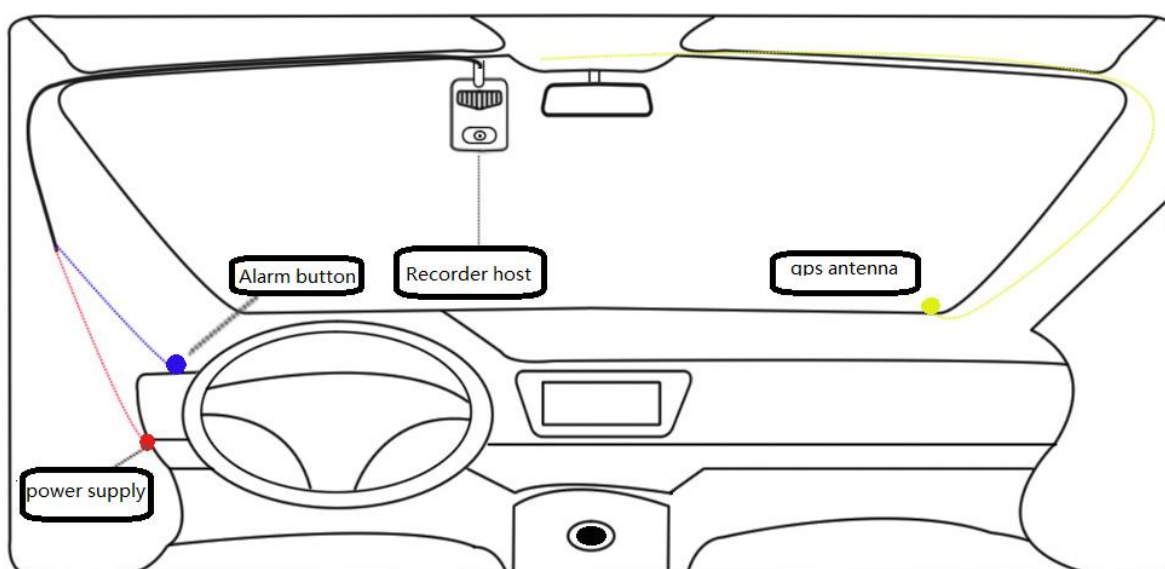

"Connection instructions:"

Wire Definition

Main power cord label : PWR

version	Serial Number	Wire color	define	describe	interface
Standard version wiring harness	1	Red (Red line)	B+	Power input positive pole, input voltage 9-36V, connected to the positive pole of the car battery	bare wire
	2	Black (Black line)	GND	Ground wire, connected to the negative pole of the car battery	bare wire
	3	Yellow (Yellow line)	ACC	Used to connect car ACC and detect vehicle ignition status	bare wire
	4	White (White line)	SOS	SOS emergency alarm button	SM-A docking interface
	5	Blue (Blue line)			
	5	Orange (Orange line)	RIGHT-IN	Connect the right turn signal wire	bare wire
	6	Green (Green Line)	LEFT-IN	Connect the left turn signal wire	bare wire
Customized wiring harness	7	Black (Black line)	GPS	4PIN BMW head harness, external GPS module	4pin BMW Head
	8	Black (Black line)	AHD1	Third AHD camera input (reserved)	4pin BMW Head
	9	Purple (Purple line)	Tx	RS232 Tx, signal output	4PIN MOLEX
	10	Brown (Brown line)	Rx	RS232 Rx, signal input	
	11	Pink (Pink line)	5V	5V output	
	12	Black (Black line)	GND	RS232 around	

Standard version wire:

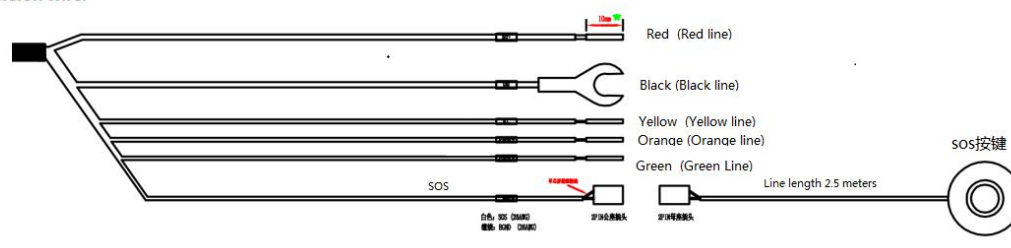

6. Viidure APP settings

6.1. ViidureAPP installation and preparation

Download: Download and install the "viidure" app from the mobile app store.

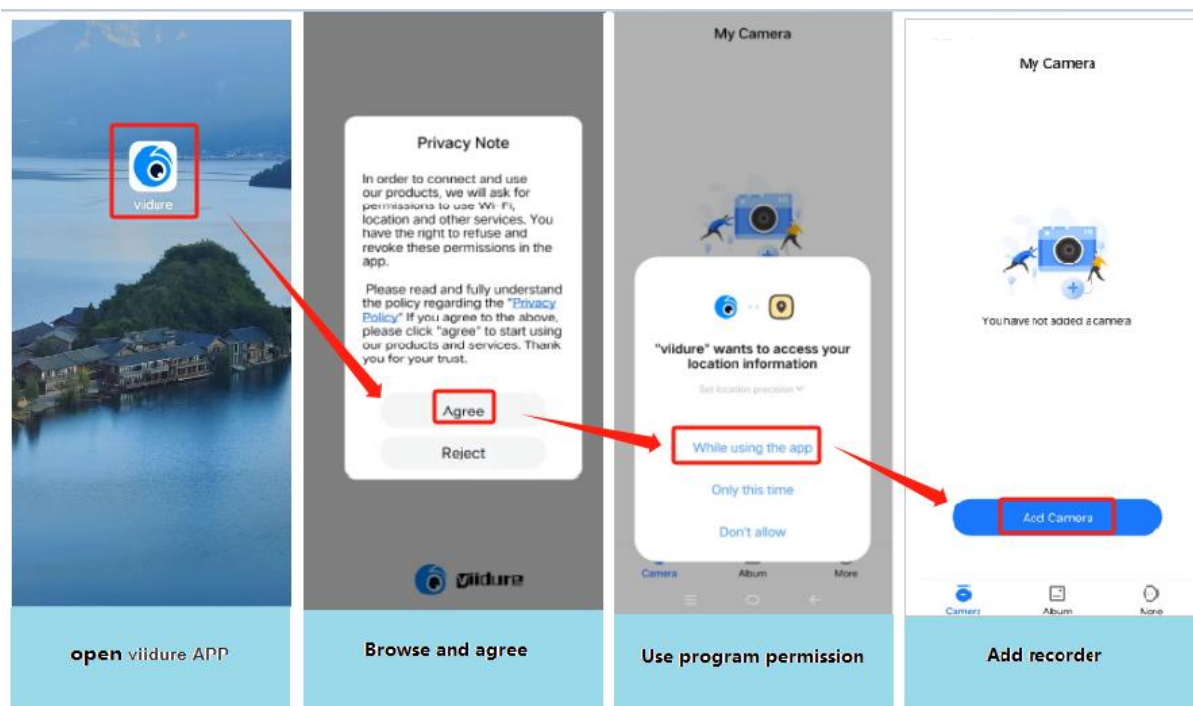

6.2. Connect AD600 in the app.

According to the instructions in the app, connect to the device's WiFi. Press the WiFi button on the device to turn on WiFi.

Warning: An AD600 device can only be connected to one mobile phone at a time, otherwise errors may occur.



Interface steps:

Step 1: Install and connect the power supply according to the installation instructions

Step 2: Add connect wifi

Step 3: Jump to wifi connection starting with at601-, initial password: 12345678, And return to the app application

Step 4: Click on the connection to enter

6.3. Recorder Settings - Algorithm Settings

After connecting AD600, click on the recorder settings - algorithm settings to ensure the rendering of ADAS/DMS is turned on.

Click on the recorder

Select camera settings

Select AI settings

Confirm that Adas and DMS rendering are turned on

Note: Filling in the device location parameters in advanced settings can make the algorithm more

accurate (optional).

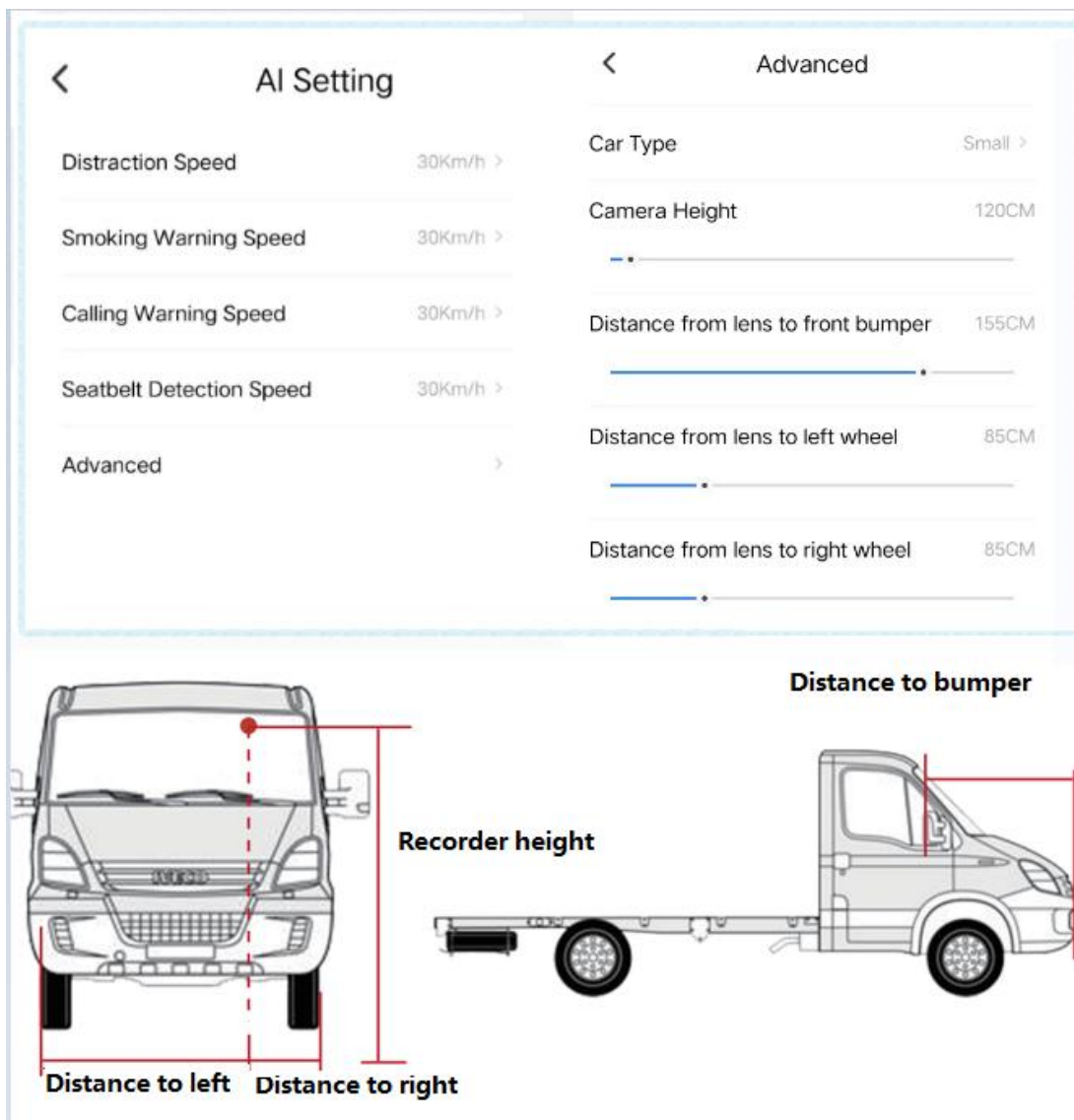

6.4.ADAS & DMS Calibration

After connecting to AD600, the real-time captured data will be sent back.

Note: ADAS and DMS calibration will only continue when the driving speed is >20km/h, otherwise the calibration progress (0~100%) will pause.

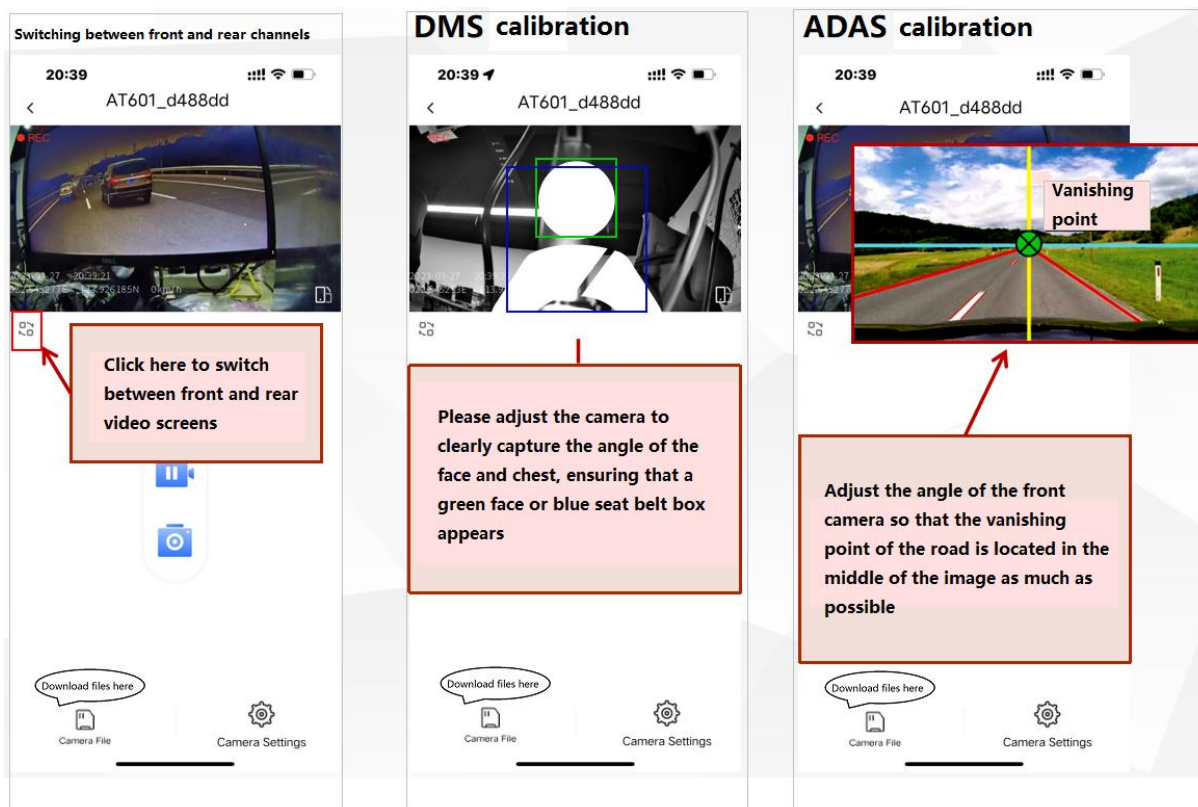

6.5 Platform Parameter Settings

After connecting to AD600, enter the recorder settings interface - platform settings - input platform parameters - click confirm (supports dual platforms).

Supports 808 2013/2019 and 905 protocols.

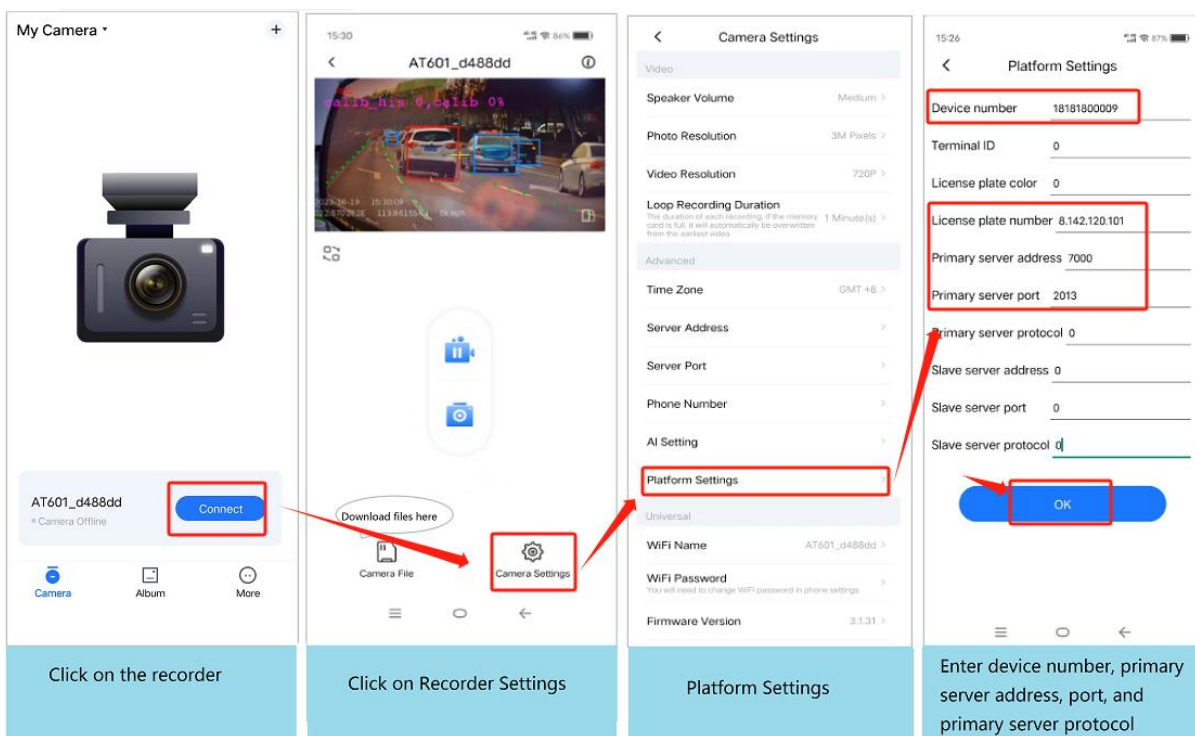

7. Firmware upgrade

Method 1: Upgrade using the app.

1. Prepare a 16GB~128GB storage card.
2. Insert it into the machine and format it with the app.
3. Use the computer to place the upgrade package "SigmastarUpgradeSD.bin" in the root directory of the storage card.
4. Insert the card with the upgrade package into the device.
5. Power on and open the device.
6. Connect the device with the app and click on "Recorder Settings - Firmware Version".
7. Wait for 1-3 minutes, the device will restart and emit a beep sound.

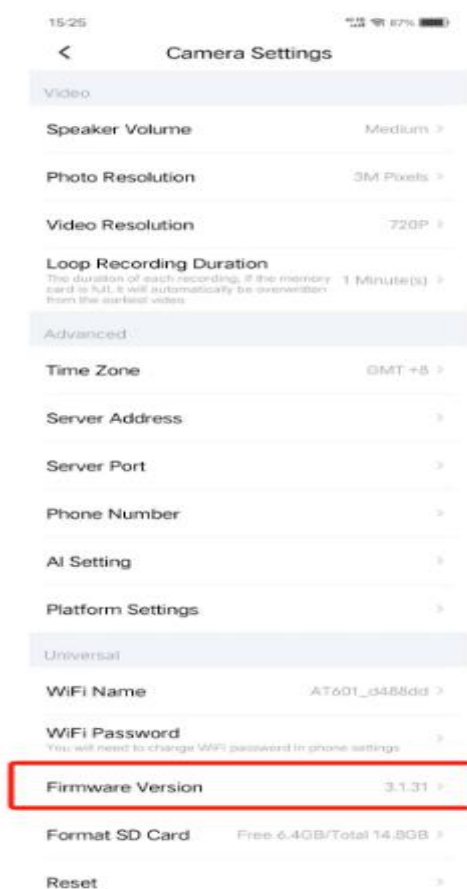

The table below shows the LED status when upgrading through the app. Steps 2-5 in the table are the upgrade process. Please do not turn off the power or operate the device.

Step	LED status
1. Prepare for an upgrade	● Blue - Yellow - Green
2. Press "Firmware Version".	● Close - Close - Close
3. Start upgrading/upgrading process	● Purple - Yellow - Green

4. Device startup and configuration	<ul style="list-style-type: none"> ● Blue - yellow or off - green or off ● Power on sound
5. Upgrade configuration completed, start recording.	<ul style="list-style-type: none"> ● Red - Yellow or Off - Green or Off

Method 2: Forced flashing, used in case of device firmware damage.

1. Prepare a storage card that is smaller than 32GB.
2. Insert it into the computer and select the FAT32 format for formatting.
3. Put all upgrade files in the root directory of the storage card, including "IPL, IPL_CUST, UBOOT, SigmastarUpgradeSD.bin".
4. Insert the card with the upgrade file into the device.
5. Power on the device, but there is no response from the device.
6. Wait for 1-3 minutes, the device will power on and emit a beep sound.

The following table shows the LED changes when flashing the firmware through an SD card. Steps 2-4 in the table are the upgrade process. Please do not turn off the power or operate the device.

Step	LED status
1. Insert SD card with upgrade file.	<ul style="list-style-type: none"> ● Close - Close - Close
2. Turn on the device power. Start upgrading/upgrading process	<ul style="list-style-type: none"> ● Close - Close - Green
3. The device starts up and configures.	<ul style="list-style-type: none"> ● Blue - yellow or off - green or off ● Power on sound
4. Upgrade configuration completed, start recording.	<ul style="list-style-type: none"> ● Red - Yellow or Off - Green or Off

Problem	Solution
Recording invalid	Please use FAT32 and a storage card with a read/write speed of at least C10.
Loop recording is invalid.	Please check if there is enough space on the storage card for recording. If there is not enough space, please format the storage card.

The video is blurry.	Please remove the protective film from the camera lens and clean the lens and windshield.
There is no audio in the recording.	Please make sure you have enabled the recording function in the app.
Device temperature is too high.	The AI function of the device requires a large amount of computation during operation, which causes the body to heat up, especially in the area of the heat sink. Please do not touch the heat sink to avoid burns.
The files on the storage card cannot be displayed on the computer.	Please use a different video player to play. If it still doesn't work, it may be due to a damaged memory card. Please try formatting or replacing it with a new memory card.
Others	If the above problem still cannot be resolved, please restore all settings to factory settings or contact local technical support for further assistance.

8. Usage precautions

8.1 Warning

The danger driving alerts issued by active safety artificial intelligence devices cannot replace the driver's driving decisions and operations.

The dangerous driving alerts issued by active safety artificial intelligence devices are developed based on computer vision and deep learning technology, and cannot guarantee 100% recognition accuracy. For example, the accuracy of the algorithm's recognition varies under different road conditions and weather conditions.

This device is designed to help users improve their understanding of driving conditions when used correctly. If used improperly, users may be distracted, leading to accidents, resulting in property damage or personal injury. Do not attempt to view stored information or change device settings while driving. Only operate this device when your vehicle is in a stationary position and parked in a safe location in accordance with local laws. Please always be aware of your surroundings and do not let the screen or phone distract you. Focusing on devices may lead to driving dangers. The risk of using this device will be borne by the user.

When installing the device on a vehicle, please do not place it in a position that obstructs the driver's view of the road or interferes with the operation and control of the vehicle, such as the steering wheel, pedals, or gear lever. Do not place it on the vehicle dashboard without fixing it. Do not place the device in front of or on top of any safety airbag.

Some countries or regions prohibit or restrict drivers from playing videos on devices. Please comply with the relevant laws in each area.

8.2 Maintenance Precautions

1. Please keep the device dry. Do not let devices and cables stay in a damp environment, and do not operate devices with wet hands to avoid equipment short circuit, corrosion-induced failures, or electric shock to personnel.
2. Please avoid subjecting the device to strong impacts or vibrations to prevent equipment malfunctions.
3. Please do not place the device and power supply in excessively high or low temperatures, as it may cause equipment malfunctions.
4. Please do not hit, throw, or puncture the equipment, and also avoid dropping or squeezing the equipment.
5. Please do not use unofficially approved or provided power and data cables.
6. Please do not disassemble the equipment and accessories without authorization, otherwise the equipment and accessories will not be covered under warranty.

8.3 Simple Troubleshooting

Problem	Solution
Recording invalid	Please use FAT32 and a storage card with a read/write speed of at least C10.
Loop recording is invalid.	Please check if there is enough space on the storage card for recording. If there is not enough space, please format the storage card.
The video is blurry.	Please remove the protective film from the camera lens and clean the lens and windshield.
There is no audio in the recording.	Please make sure you have enabled the recording function in the app.
Device temperature is too high.	The AI function of the device requires a large amount of computation during operation, which causes the body to heat up, especially in the area of the heat sink. Please do not touch the heat sink to avoid burns.
The files on the storage card cannot be displayed on the computer.	Please use a different video player to play. If it still doesn't work, it may be due to a damaged memory card. Please try formatting or replacing it with a new memory card.
Others	If the above problem still cannot be resolved, please restore all settings to factory settings or contact local technical support for further assistance.

9. Conclusion

Thanks to the support and cooperation of our customers, we can thrive and endure!

We can steadily move forward precisely because of the hard work and dedication of our colleagues!

Let us explore the highlights of technology with a unique perspective, let us strive to raise the sails of our ideals, and embark on the journey of pursuing technology!